

6.6 GHz WiFi 6E Coexistence BAW Filter

A10166

Description

Akoustis’ A10166 is a high-performance, ultra-wide bandwidth BAW RF Filter for use in WiFi 6E applications covering portions of U-NII-5 thru U-NII-8 bands. A10166 utilizes Akoustis’ patented XBAW® technology which provides leading RF filter performance. This BAW RF filter provides low insertion loss and meets the stringent rejection requirements enabling coexistence with U-NII-1 thru 4. This device exhibits high-power handling capabilities necessary for demanding power requirements of the latest WiFi 6E standards. A10166 is a fully integrated, 50Ω module using standard laminate packaging and is compatible with high volume, lead-free SMT soldering processes.

- Small form factor 3.5mm x 3.5mm x 1.74mm
- Single-ended Tx/Rx ports.
- Ultra-wide passband covering 1020 MHz
- High rejection enables coexistence with adjacent WiFi UNII bands
- High power rating, maximum +27 dBm
- Low insertion loss band-pass filter
- Performance over -20 C to +95C
- RoHS compliant, Pb-free package

Applications

- WiFi 6E tri band routers, integrated cable modem
- WiFi 6E tri band access points
- LTE/LAA small cells

Functional Block Diagram

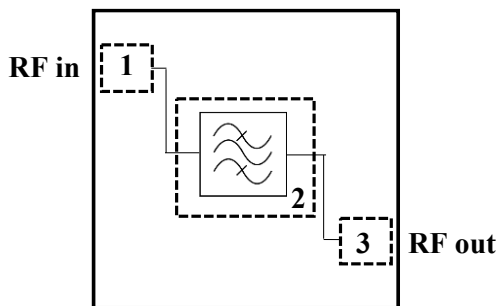

Pin #	Description
1	RF Input
2	Ground
3	RF Output

Ordering Information

Part Number	Description
A10166EVB	Evaluation board
A10166SP	(5) Loose pcs
A10166SR	(100) Short Reel (7" Reel)
A10166TR1	(1000) Tape & Reel (7" Reel)
A10166TR2	(2500) Tape & Reel (13" Reel)

Absolute Maximum Ratings

Parameter	Conditions	Rating
Storage Temperature		-40 to 125 °C
Max Input Power	Signal: OFDM MCS0, 80MHz, PAR 10dB	+29 dBm
Max Temperature		-40 to 105°C

Exceeding any one limit or a combination of AMR conditions may result in damage to the device.

Operating Parameters (Temp = 25°C unless otherwise noted)

Parameter	Conditions	Units	Min.	Typ.	Max.
Passband		MHz	6105	6615	7125
Insertion Loss	6105 – 6125 MHz	dB		2.3 ⁽¹⁾	2.8 ⁽²⁾
	6125 – 7125 MHz	dB		1.7 ⁽¹⁾	2.4 ⁽²⁾
Amplitude Variation	6105 – 7125 MHz	dB		1.0 ⁽²⁾	1.3 ⁽²⁾
Attenuation	30 – 2700 MHz	dB	26	28	
	3300 – 4200 MHz	dB	8	11	
	4200 – 4900 MHz	dB	6	8	
	5170 – 5785 MHz	dB	42	45	
	5785 – 5895 MHz	dB	44	46	
	8500 – 12000 MHz	dB	11	14	
Return Loss	6105 – 7125 MHz		10	17 ⁽¹⁾	
Load Impedance		Ω		50	
Power Handling	OFDM MCS0, 80MHz, PAR 10 dB	dBm			27

Note:

1. Averaged over specified frequency at room temperature
2. Averaged over 20MHz channel

Operating Parameters (Temp = -20°C to +95°C unless otherwise noted)

Parameter	Conditions	Units	Min.	Typ.	Max.
Passband		MHz	6105	6615	7125
Insertion Loss	6105 – 6125 MHz	dB		2.3 ⁽¹⁾	3.0 ⁽²⁾
	6125 – 7125 MHz	dB		1.7 ⁽¹⁾	2.4 ⁽²⁾
Amplitude Variation	6105 – 7125 MHz	dB		1.0 ⁽²⁾	1.3 ⁽²⁾
Attenuation	30 – 2700 MHz	dB	25	28	
	3300 – 4200 MHz	dB	8	11	
	4200 – 4900 MHz	dB	4	8	
	5170 – 5785 MHz	dB	42	45	
	5785 – 5895 MHz	dB	44	46	
	8500 – 12000 MHz	dB	10	14	
Return Loss	6105 – 7125 MHz	dB	10	17 ⁽¹⁾	
Load Impedance		Ω		50	
Power Handling:	OFDM MCS0, 80MHz, PAR 10dB	dBm			27

Note:

1. Averaged over specified frequency at room temperature
2. Averaged over 20MHz channel

A10166

EVB Schematic & Layout

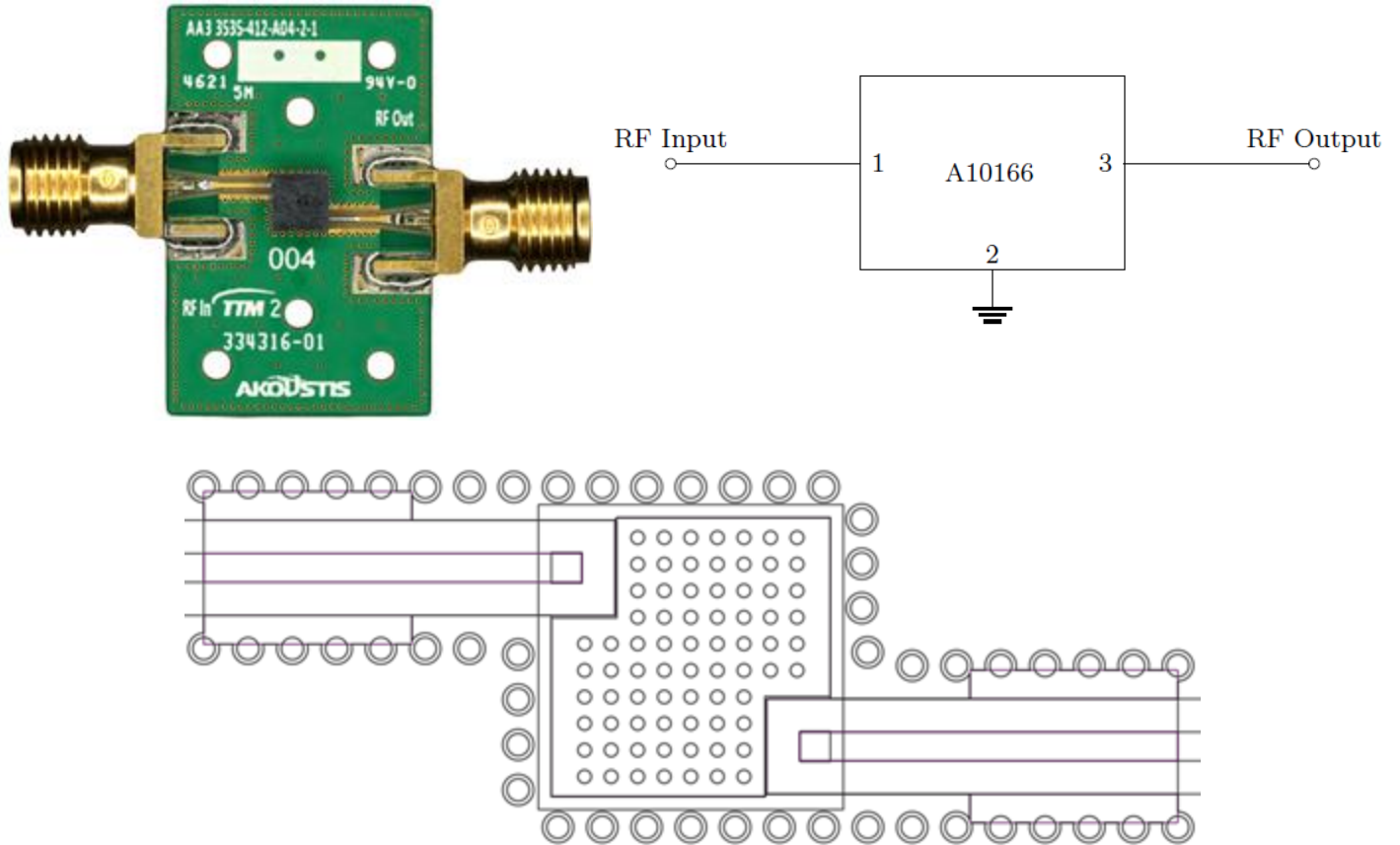

Note:

- 1) Center ground pad vias 6mil diameter
- 2) RF ground vias 10mil diameter

Bill of Materials

Reference Des.	Value	Description	Manufacturer	Part Number
PCB	N/A	Multi layer	Multiple	AA33535-412-A04-2-1
U1	N/A	6.6 GHz BAW Filter	Akoustis	A10166

Performance Plots (Temp = 25°C unless otherwise noted)

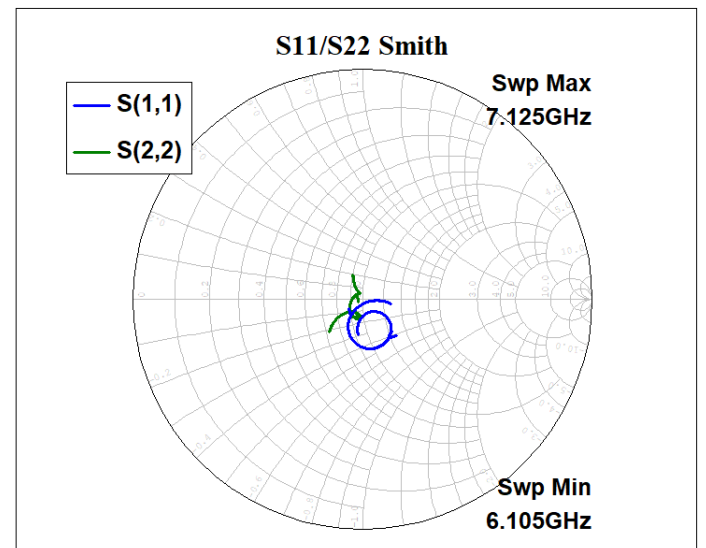
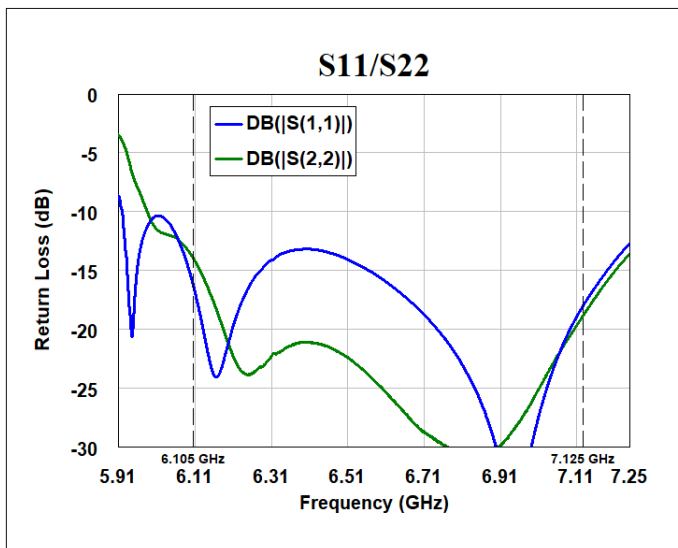
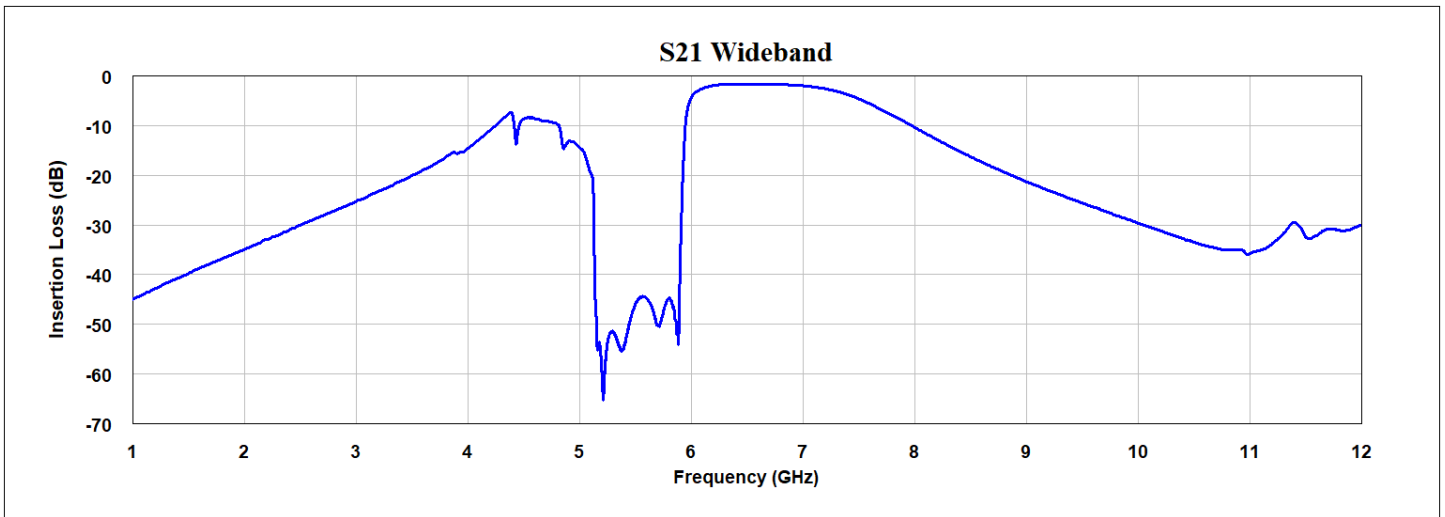
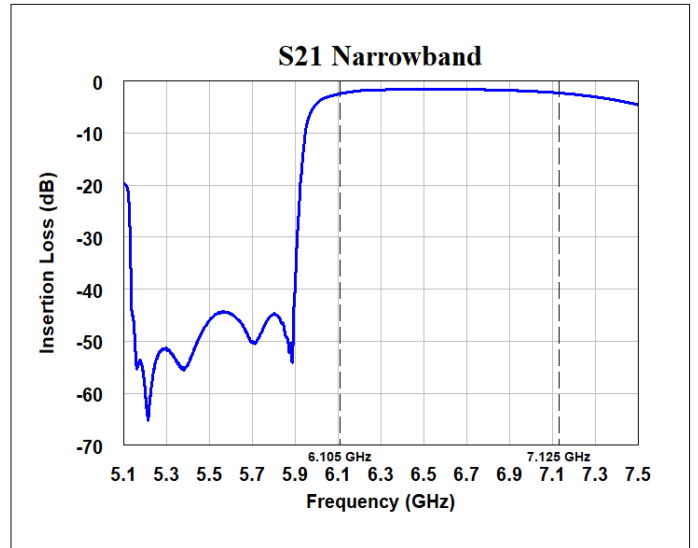
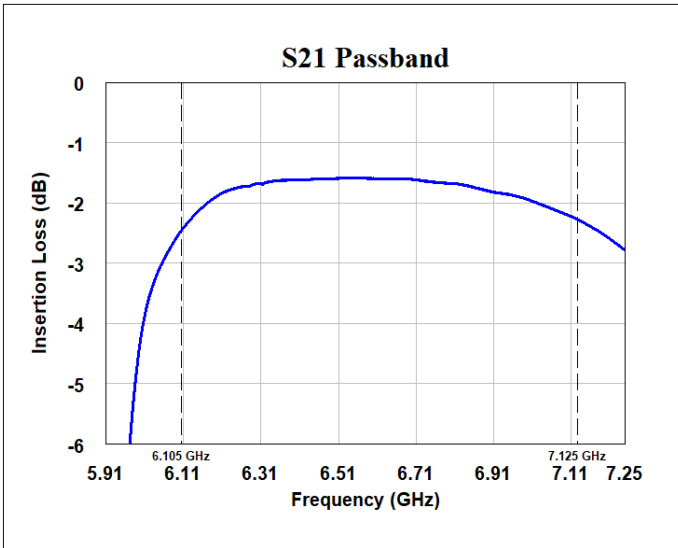

Package Drawing & Pin Description

Notes:

- All Units are in mm unless otherwise stated
- General Tolerance:
Linear X.XXX = $\pm 0.050\text{mm}$
X.XX = $\pm 0.10\text{mm}$
- Terminal Finish:
Electroless Ni/Electroless Pd/Immersion Au

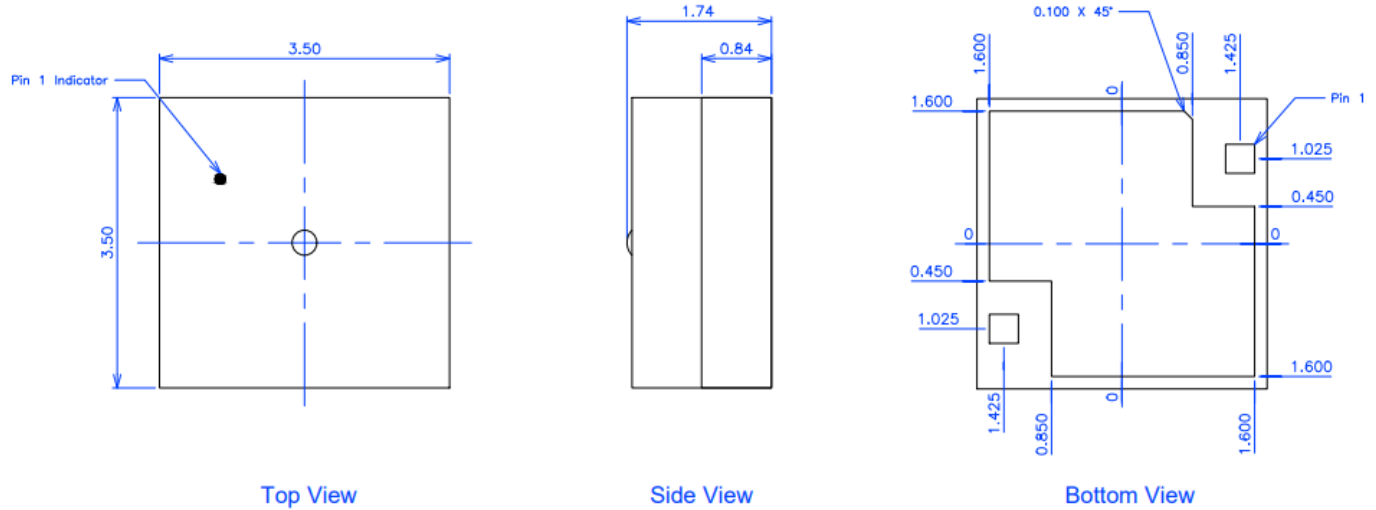

PCB Mounting Pattern

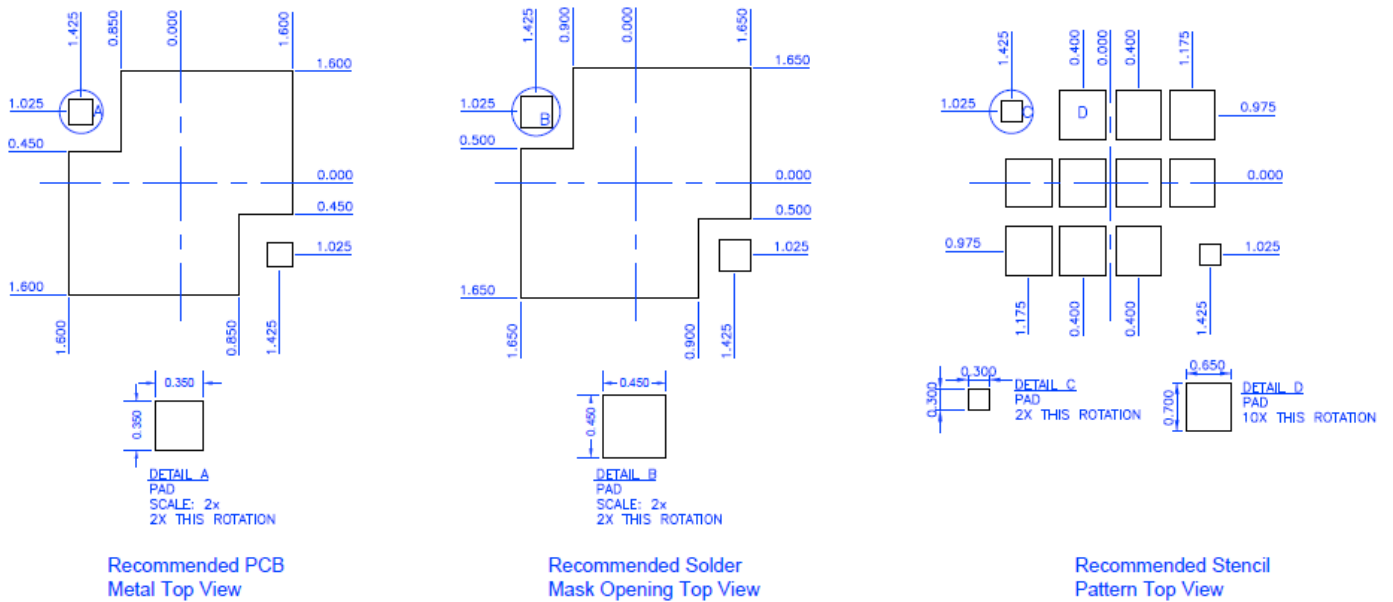

Typical Part Marking

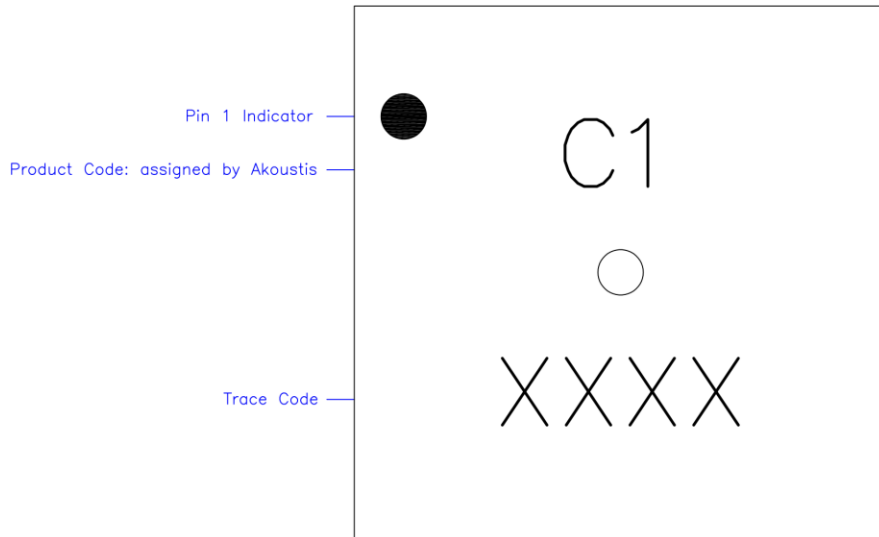

Reel Dimensions

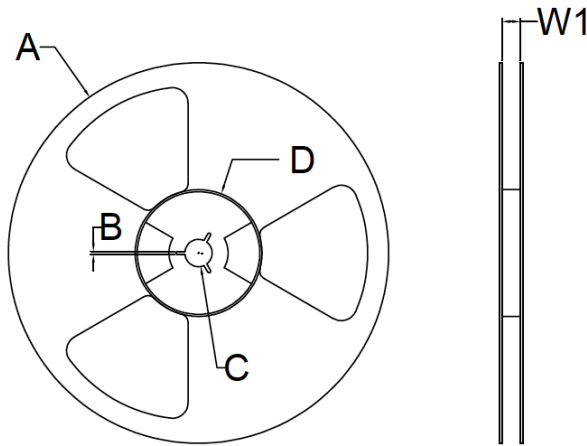

Reel Dimensions						
Reel Size	Tape Width	A	B	C	D	W1 *measured at hub
7 Inch	8 mm	180 +0/-2.0 mm	2.0mm +/-0.5	13.0 +0.5 / -0 mm	60.0 +/- 2.0 mm	8.40 + 1.5 / -0 mm
	12 mm	180 +0/-2.0 mm	2.0mm +/-0.5	13.0 +0.5 / -0 mm	60.0 +/- 2.0 mm	12.40 + 2.0 / -0 mm
	16 mm	180 +0/-2.0 mm	2.0mm +/-0.5	13.0 +0.5 / -0 mm	60.0 +/- 2.0 mm	16.40 + 2.0 / -0 mm
13 Inch	8 mm	330 +/- 2.0 mm	2.0mm +/-0.5	13.0 +0.5 / -0.2 mm	102 +/- 2.0 mm	8.8 + 2.0 / -0 mm
	12 mm	330 +/- 2.0 mm	2.0mm +/-0.5	13.0 +0.5 / -0.2 mm	102 +/- 2.0 mm	12.8 + 2.0 / -0 mm
	16 mm	330 +/- 2.0 mm	2.0mm +/-0.5	13.0 +0.5 / -0.2 mm	102 +/- 2.0 mm	16.8 + 2.0 / -0 mm

Note: 7 Inch Reel Only Has One Opening

Tape Dimension

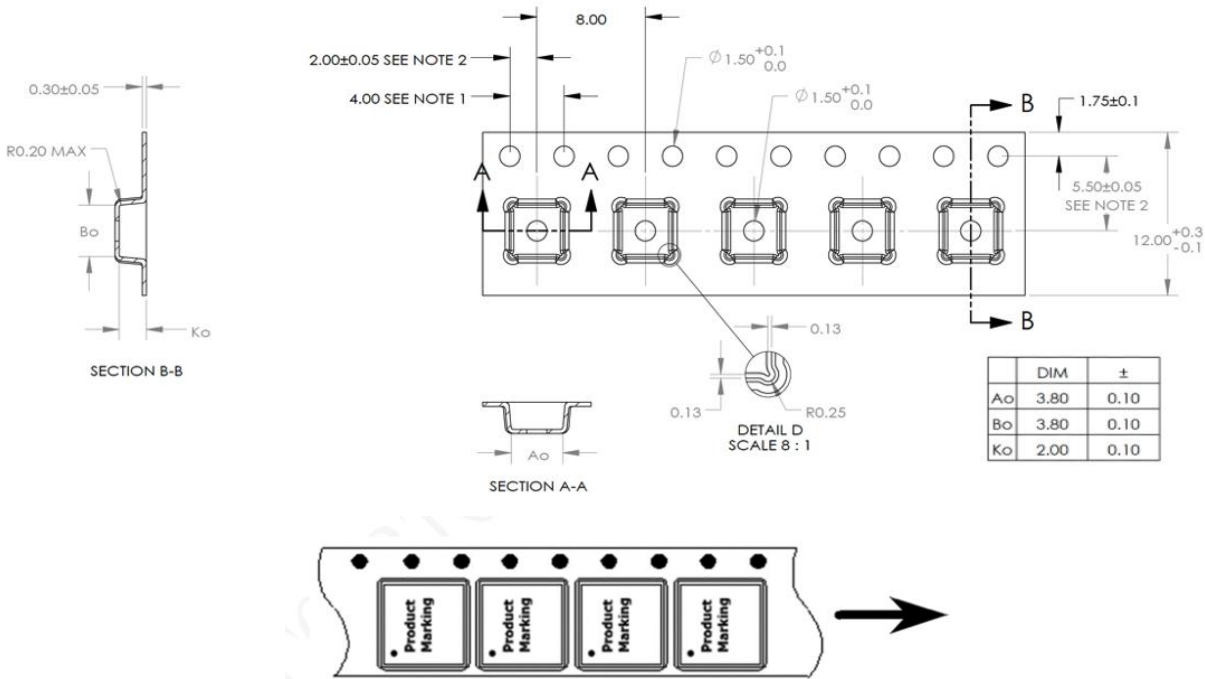

Recommended Solder Profile

Parameter	Eutectic Sn/Pb	Pb Free
Max Ramp Up Rate	6 Deg C/Second	6 Deg C/Second
Soak Temp Time $T_S(\text{min}) - T_S(\text{max})$	135 - 155 Deg C	150-200 Deg C
Max Soak Time T_S	2 minutes	3 minutes
Liquidous Temp T_L	183 Deg C	220 Deg C
Max Time Above T_L	150 Seconds	150 Seconds
Max Peak Temperature T_P	225 Deg C	260 Deg C
Max Time at Peak T_P	30 Seconds	30 Seconds
Max Ramp Down Rate	10 Deg C/Second	10 Deg C/Second

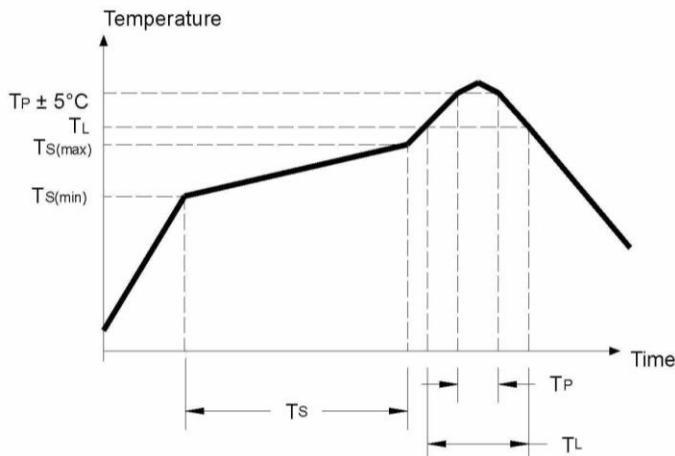

A10166

Product Compliance Information

ESD Sensitivity Ratings

Human Body Model (HBM) Test

Rating: Class 2

Standard: ANSI/ESDA/JEDEC JS-001-2017

Charged Device Model (CDM)

Rating: Class C3

Standard: ANSI/ESDA/JEDEC JS-002-2018

MSL Rating

MSL3

RoHS

This part is compliant with the 2011/65EU RoHS directive on the restrictions of the use of certain hazardous substances in electrical and electronic equipment as amended by Directive (EU) 2015/863

Contact Information

All contents specified in the datasheet are subject to change. Please contact Akoustis for the latest on our products and company information.

Email: sales@akoustis.com

Website: www.akoustis.com

Telephone: +1 704.997.5735

Fax: +1 704.997.5734